



Sveučilište u Zagrebu
**RUDARSKO
GEOLOŠKO
NAFTNI FAKULTET**

Copyright © All rights reserved by authors.



Sveučilište u
Zagrebu

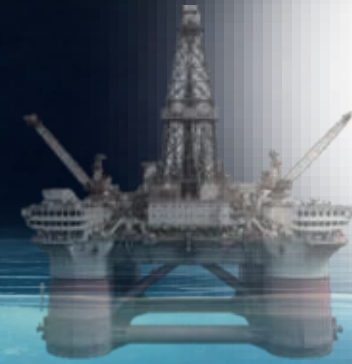

VAŽNOST MENTANSKIH HIDRATA I NJIHOVO GENERIRANJE U LABORATORIJSKIM UVJETIMA

Studenti: univ. bacc. ing. petrol. Marko Uzelac; univ. bacc. ing. petrol. Luka Uzelac

Profesori: prof. dr. sc. Tomislav Malvić; izv. prof. dr. sc. Borivoje Pašić

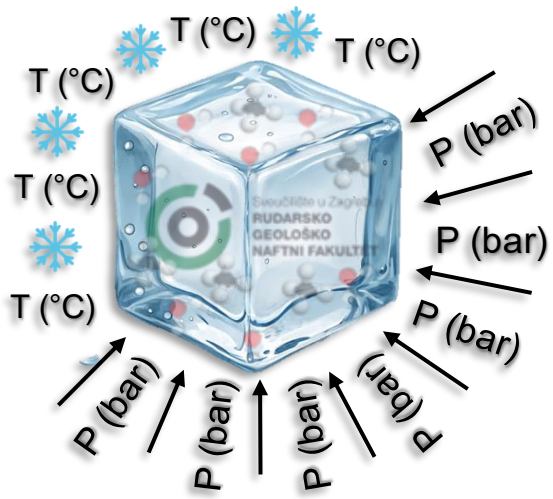

Uvod

- Što su to metanski hidrati?
- 90% (mora i oceani) → **97-99%**
- 27% (kopno) → **1-3%**
- ~ 1 milijarda \$/god
- $20000 \cdot 10^{12} \text{ m}^3$

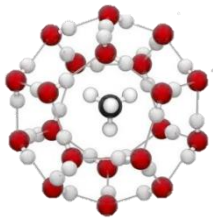

Globalna distribucija (1990 -2020)

Copyright © All rights reserved by authors.

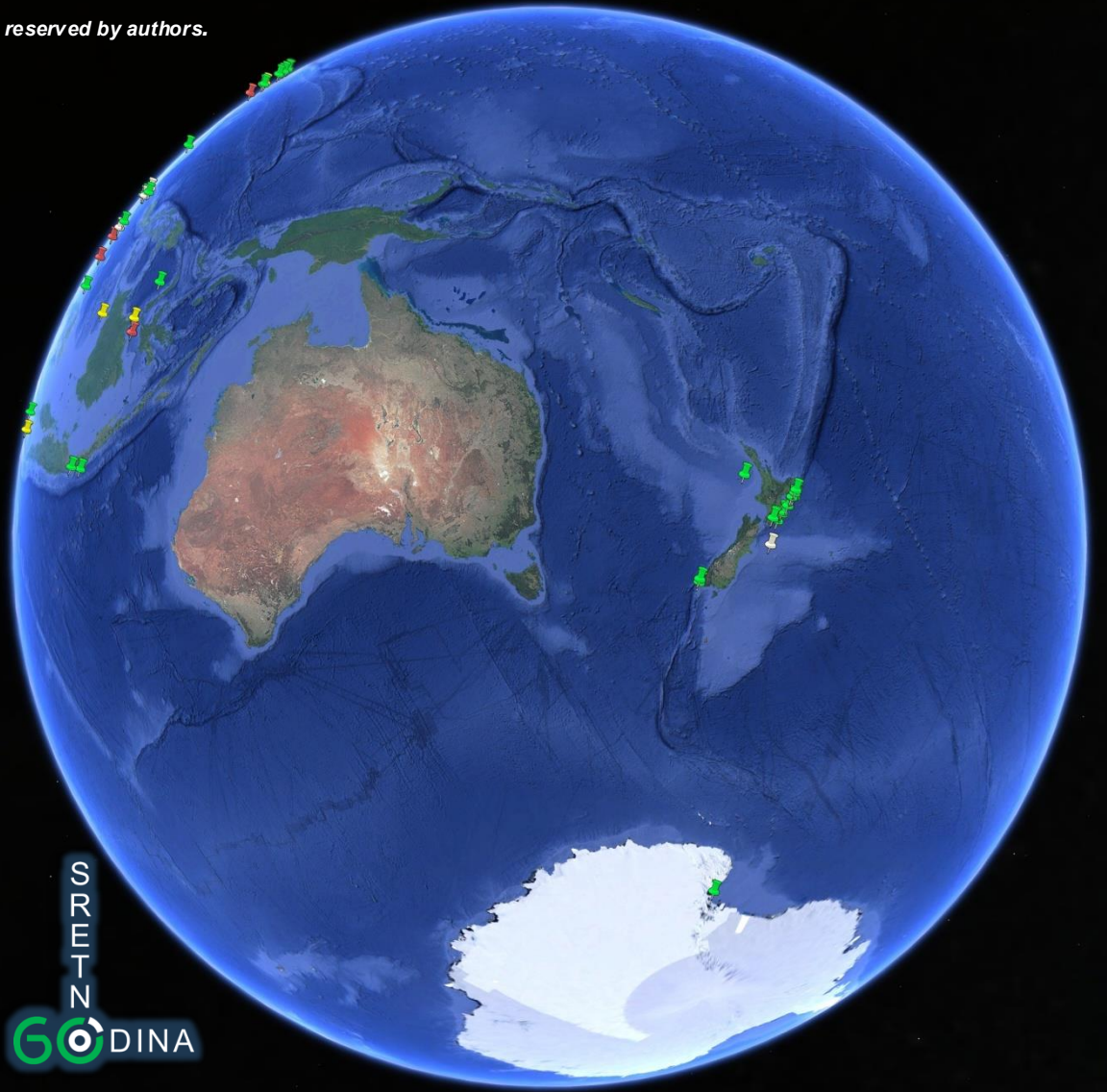
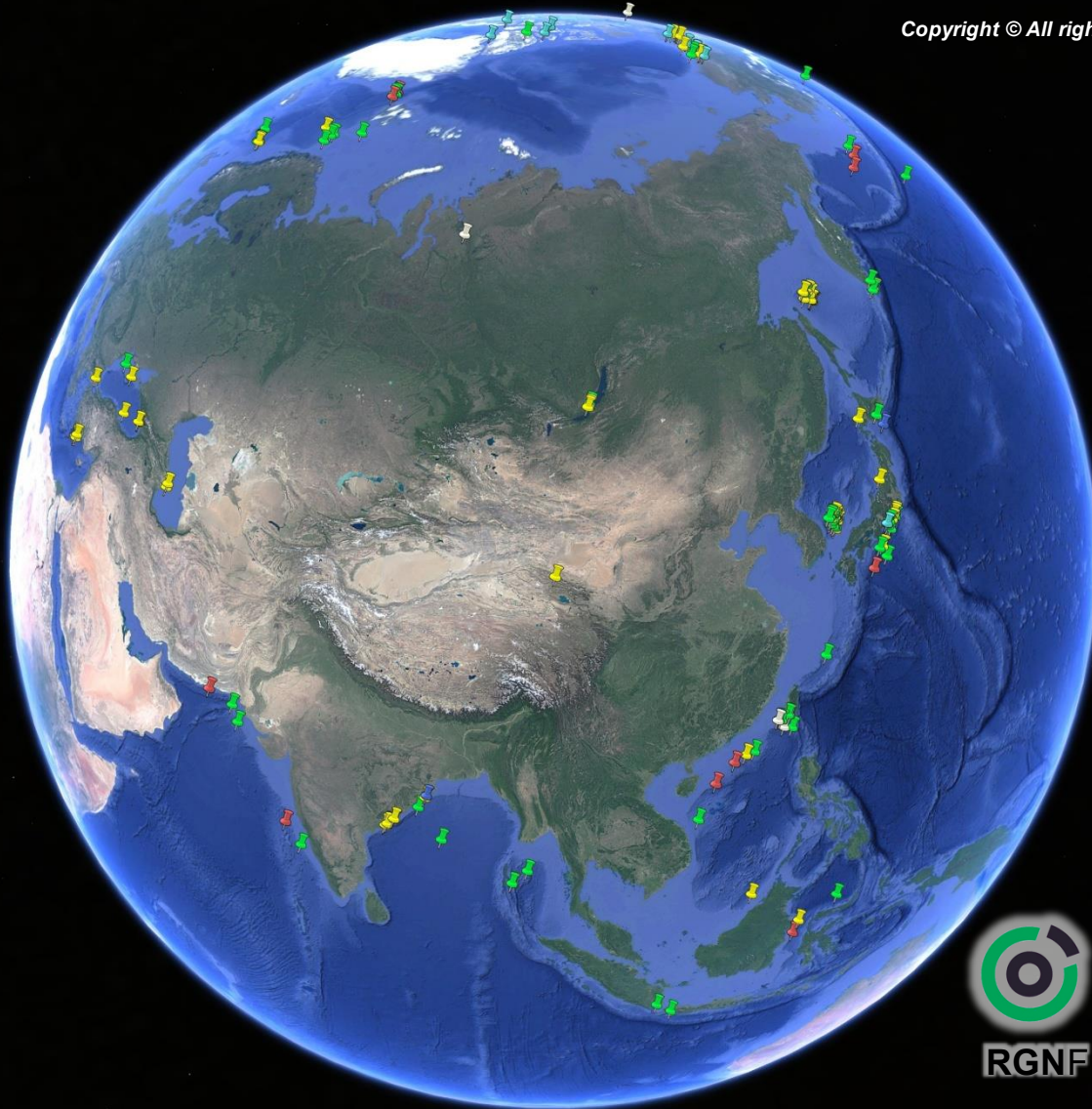



RGNF

TESTNE PROIZVODNJE IZ LEŽIŠTA METANSKIH HIDRATA

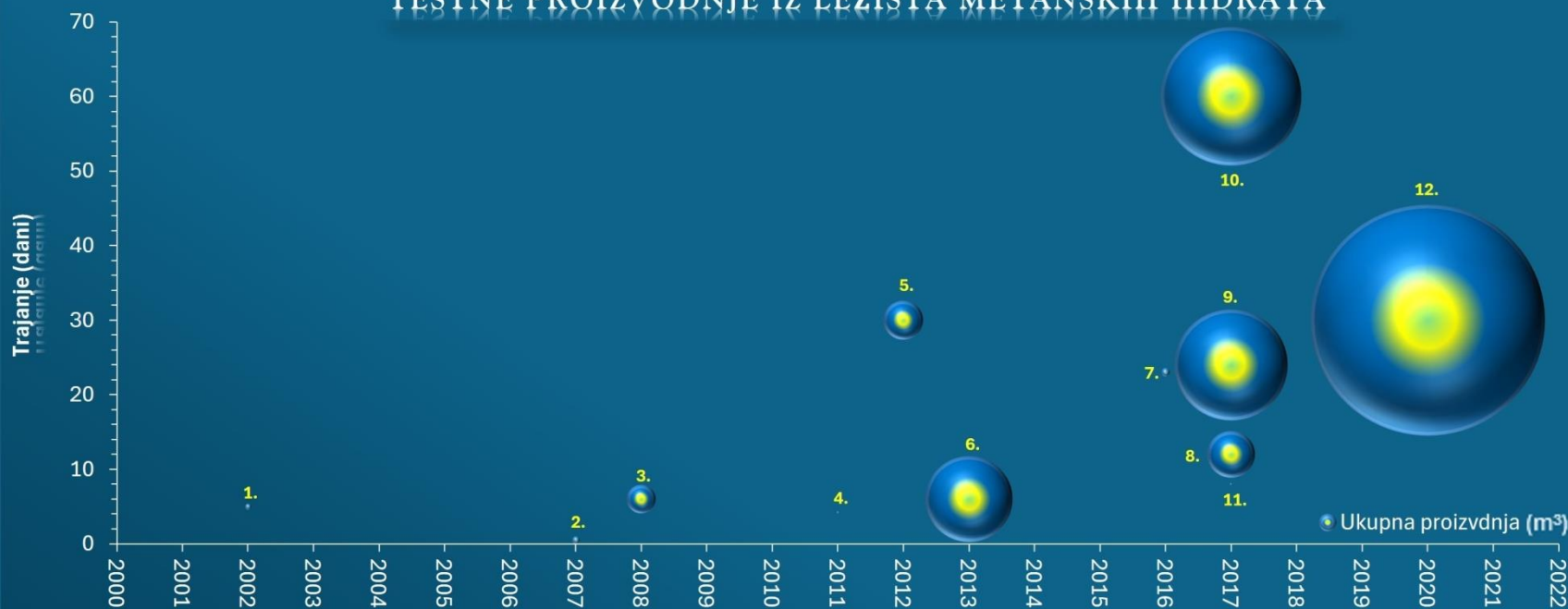

Godina	Metoda	Trajanje	Ukupna proizvodnja
1. 2002	Termalna stimulacija	5 dana	516 m ³
2. 2007	Metoda smanjenja tlaka	12.5 sati	830 m ³
3. 2008	Metoda smanjenja tlaka	6 dana	13 000 m ³
4. 2011	Termalna stimulacija + metoda smanjenja tlaka	101 sati	95 000 m ³
5. 2012	Izmjena CO ₂ -CH ₄ + metoda smanjenja tlaka	30 dana	24 000 m ³
6. 2013	Metoda smanjenja tlaka	6 dana	119 000 m ³
7. 2016	Metoda smanjenja tlaka	23 dana	1078 m ³
8. 2017	Metoda smanjenja tlaka	12 dana	35 000 m ³
9. 2017	Metoda smanjenja tlaka	24 dana	200 000 m ³
10. 2017	Modificirana metoda smanjenja tlaka	60 dana	309 000 m ³
11. 2017	Fluidizacija čvrste faze	8 dana	81 m ³
12. 2020	Metoda smanjenja tlaka	30 dana	861 400 m ³

Metode:

1. Depressurization (Metoda smanjenja tlaka)
2. Thermal stimulation (Termalna stimulacija)
3. CO₂-CH₄ Exchange (Izmjena CO₂-CH₄)
4. Formation fluid extraction (Modificirana metoda smanjenja tlaka)
5. Solid fluidization (Fluidizacija čvrste faze)





Ekonomski kriteriji:

300 000 m³/d – Permafrost
500 000 m³/d – Odobalje

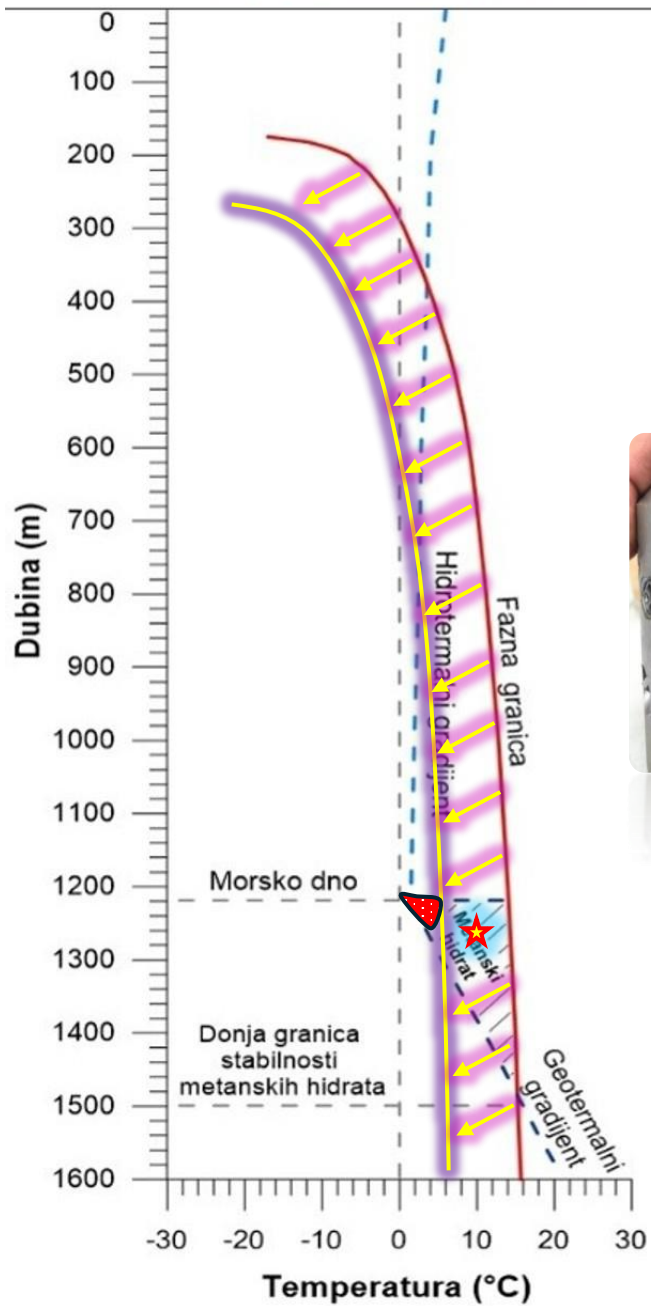
50 000 m³/d ?

Marinski okoliš -offshore



-  Početni ležišni uvjeti (P_r, T_r)
-  Depressurization (smanjenje tlaka)
-  Thermal stimulation (termalna stimulacija)
-  Termalna stimulacija + metoda smanjenja tlaka



Permafrost-onshore

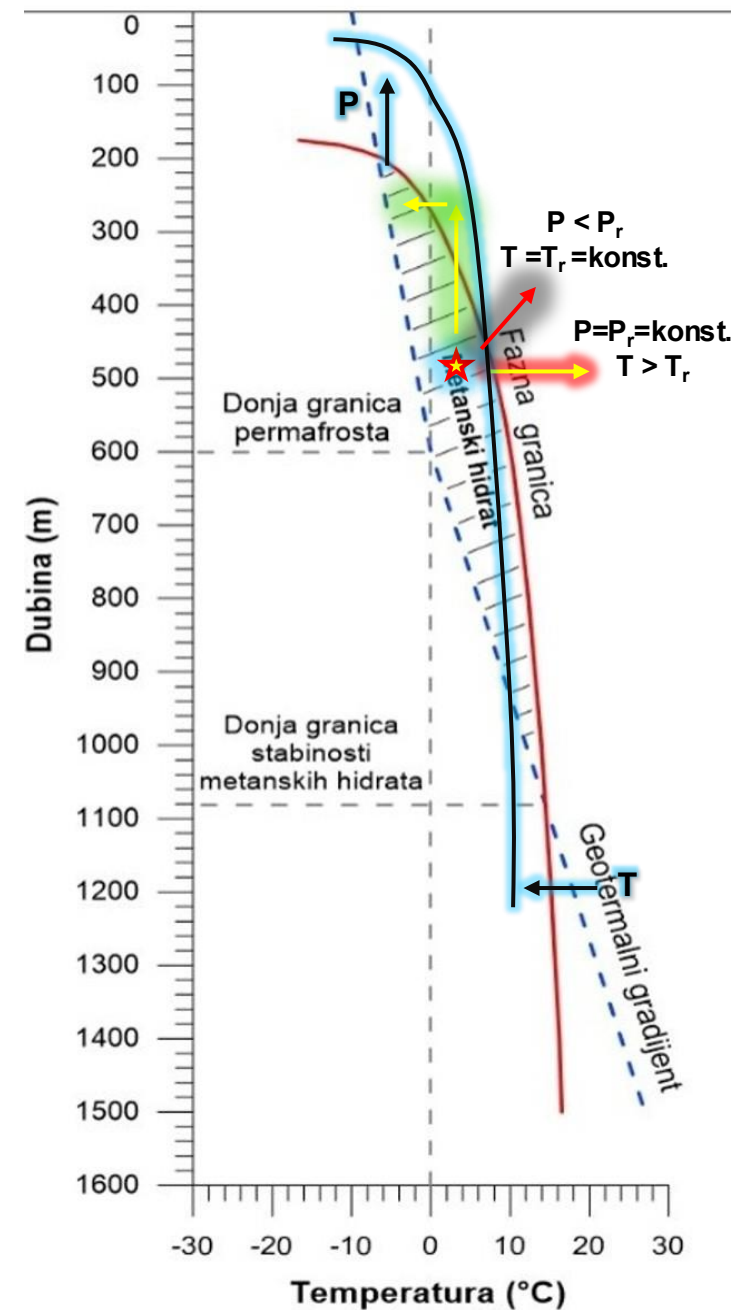

Kvaliteta ležišta

Marinski okoliš (offshore)

Permafrost (onshore)

Propusnost (nekoliko mD)

Propusnost (10-1000 mD)

Glinoviti silt

Nekonsolidirani pješčenjaci



Copyright © MH21-S



Copyright © MH21-S

$\phi \sim 40-50\%$
 $S_n \sim 50-90\%$

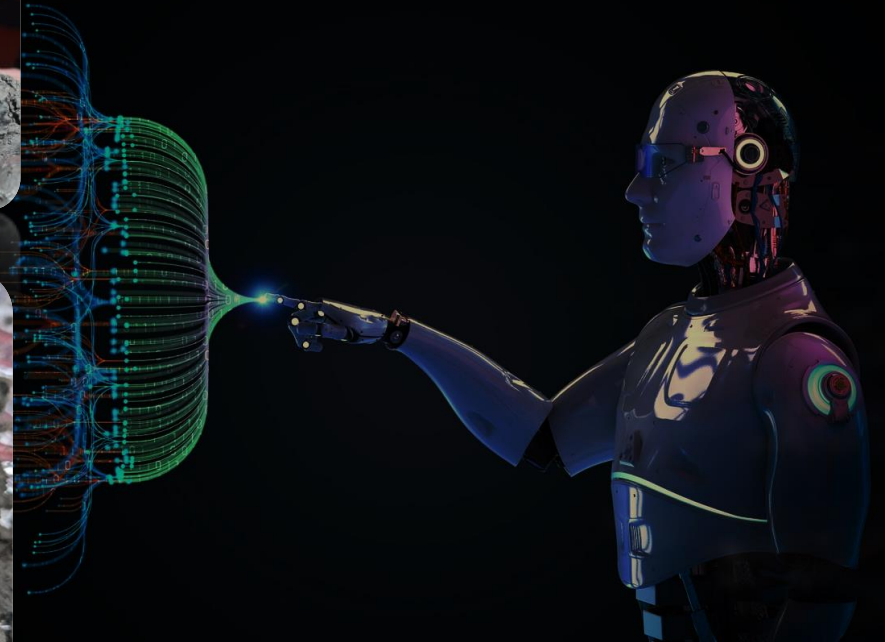

Alaska North Slope - prva dugotrajna proizvodnja
(19.9.2023 - 30.7.2024)





Problemi:



Proizvodni omjer plin-voda

Ležišta metanskih hidrata:

27.2-185.7 m³/m³

Konvencionalna plinska ležišta:

20000-89000 m³/m³

1 m³ metanskog hidrata → 164 m³ metana + 0.8-0.9 m³ vode

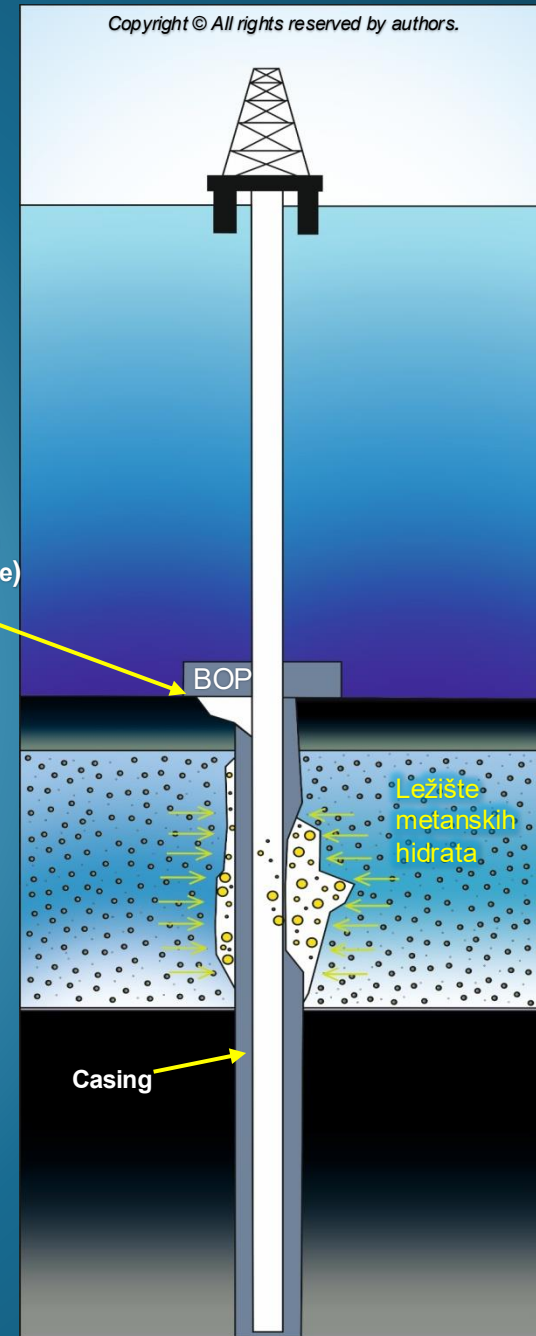

Uporabni model UM20250075

Naziv: KOMORA ZA PROIZVODNJU METANSKIH HIDRATA U LABORATORIJSKIM UVJETIMA



Sveučilište u Zagrebu

Tehnički problemi koje je bilo potrebno riješiti:

Kako osigurati da komora izdrži tolike tlakove?

Kako osigurati vizualni nadzor procesa formiranja metanskog hidrata?

Kako osigurati ponovljivost procesa formiranja metanskih hidrata?

Kako ubrzati proces formiranja metanskih hidrata?



Dizajn uporabnog modela UM20250075



DRŽAVNI ZAVOD ZA INTELEKTUALNO VLASNIŠTVO

- 1 - gornje kontrolno stakalce
- 2 - donje kontrolno stakalce
- 3 - visokotlačna spojnica cilindričnog oblika s bočnim koljenima
- 4 - T-adapter
- 5 - duga spojna cijev
- 6 - kratka spojna cijev
- 7 - protupovratni ventil
- 8 - ventil za ispušt tlaka
- 9 - metalna poluga
- 10 - manometar

Pripadajući poprečni presjeci:

- 1 & 2 → 11
- 3 → 14
- 4 → 12
- 5 → 13
- 6 → 17
- 7 → 15
- 8 → 16
- 9 → 18

Dodatno:

- 15.1 - pladanj protupovratnog ventila
- 15.2 - opruga
- 16.1 - kružni otvor
- 16.2 - vijak

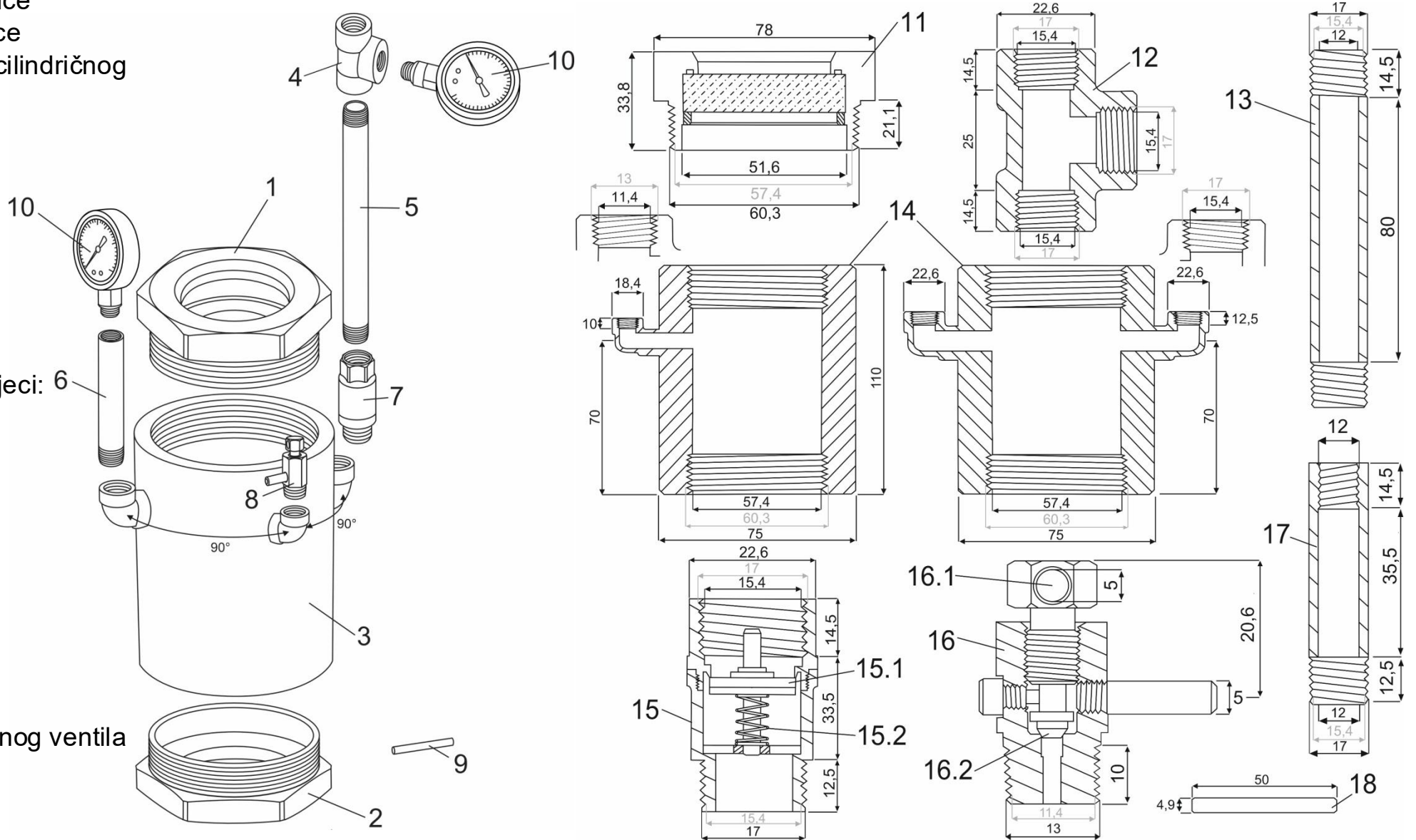

Dizajn uporabnog modela UM20250075



DRŽAVNI ZAVOD ZA INTELEKTUALNO VLASNIŠTVO

- 19 - komora
- 20 - pneumatski multiplikator tlaka plina
- 20.1 - manji klip
- 20.2 - veći klip
- 20.3 - zračna sekcija

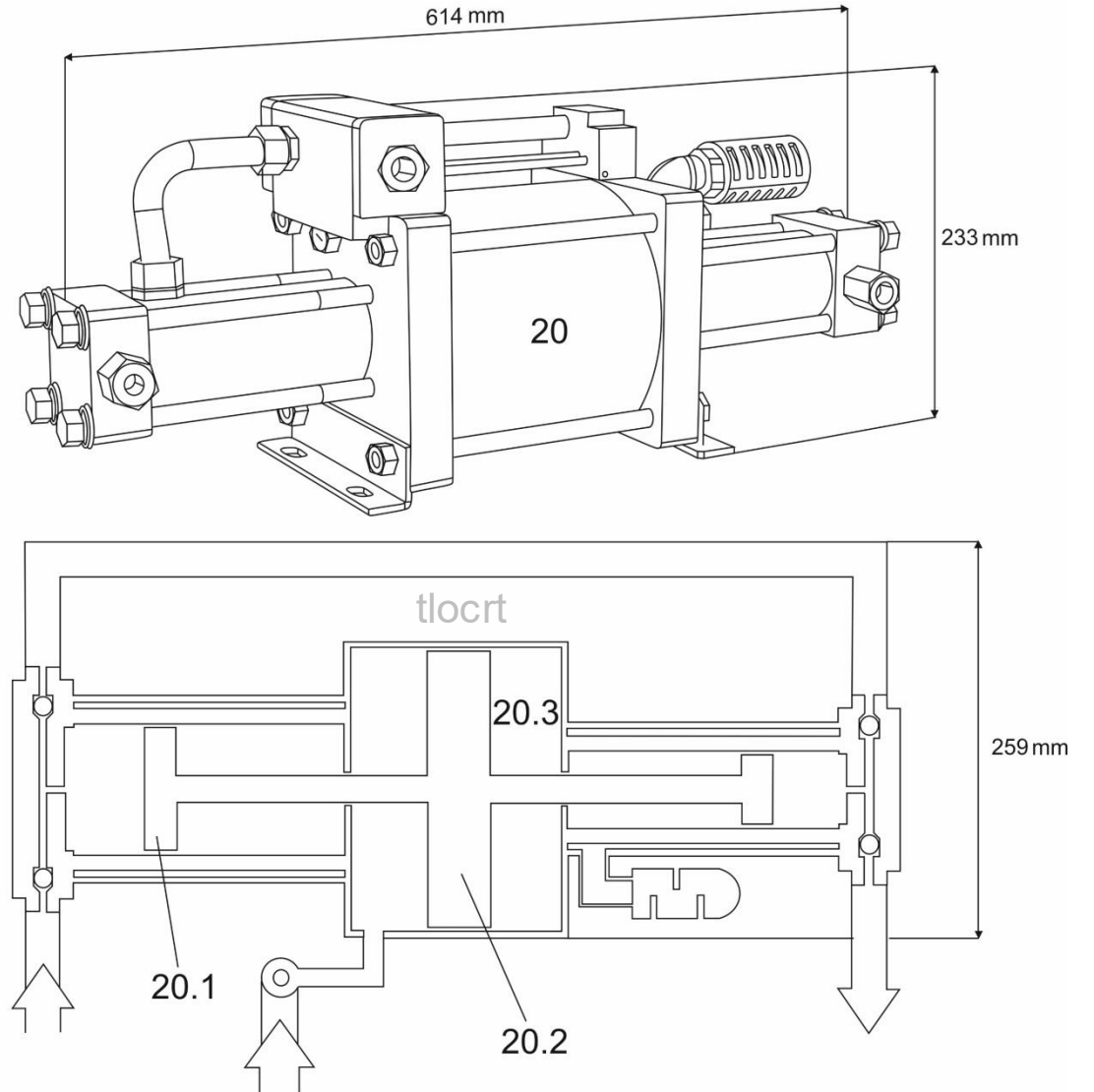
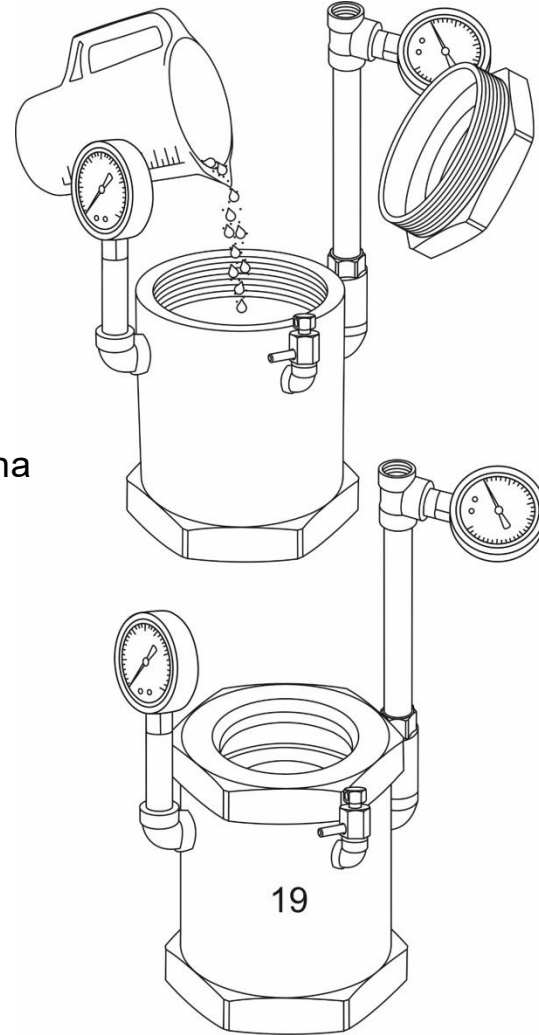

Dizajn uporabnog modela UM20250075



DRŽAVNI ZAVOD ZA INTELEKTUALNO VLASNIŠTVO

- 4 - T-adapter
- 5 - duga spojna cijev
- 6 - kratka spojna cijev
- 7- protupovratni ventil
- 8 - ventil za ispuštak tlaka
- 10 - manometri
- 19 - komora
- 20 - pneumatski multiplikator tlaka plina
- 20.4 - ulazna sekcija
- 20.5 - izlazna sekcija
- 21 - plinski cilindar
- 22 - regulator tlaka
- 23 - visokotlačno crijevo
- 24 - priključak za brzo spajanje s muškim navojnim spojem
- 25 - zračni kompresor
- 26 - zaporni ventil

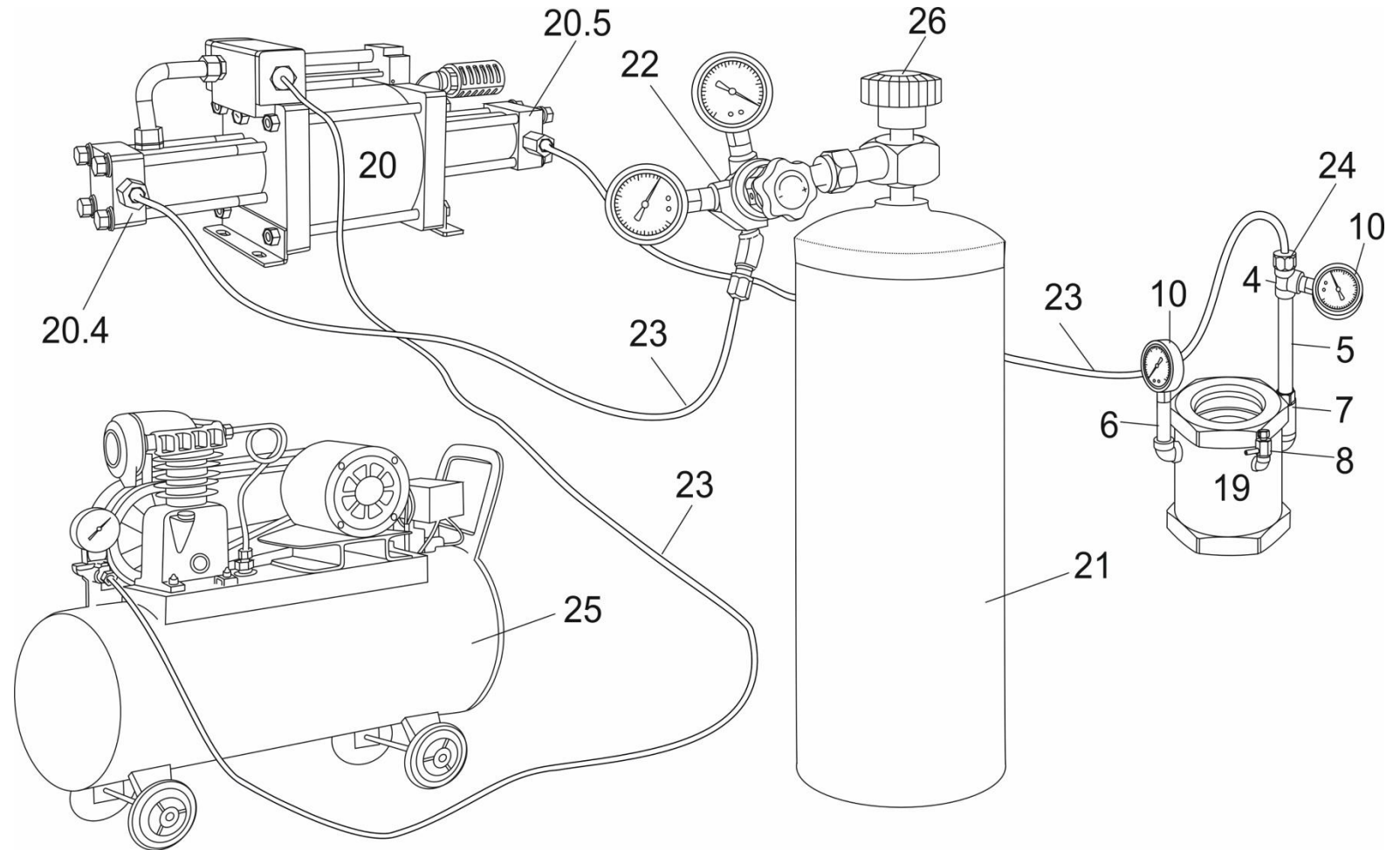

Dizajn uporabnog modela UM20250075



DRŽAVNI ZAVOD ZA INTELEKTUALNO VLASNIŠTVO

- 1 - gornje kontrolno stakalce
- 19 - komora
- 27 - aparat za vodu
- 28 - unutarnji spremnik
- 29 - temperaturni regulator
- 30 - utičnica temperaturnog regulatora
- 31 - zidna utičnica
- 32 - senzor temperaturnog regulatora
- 33 - senzor uređaja za mjerenje temperature
- 34 - kanistar
- 35 - potopna pumpa (npr. za akvarij)
- 36 - uređaj za mjerenje temperature

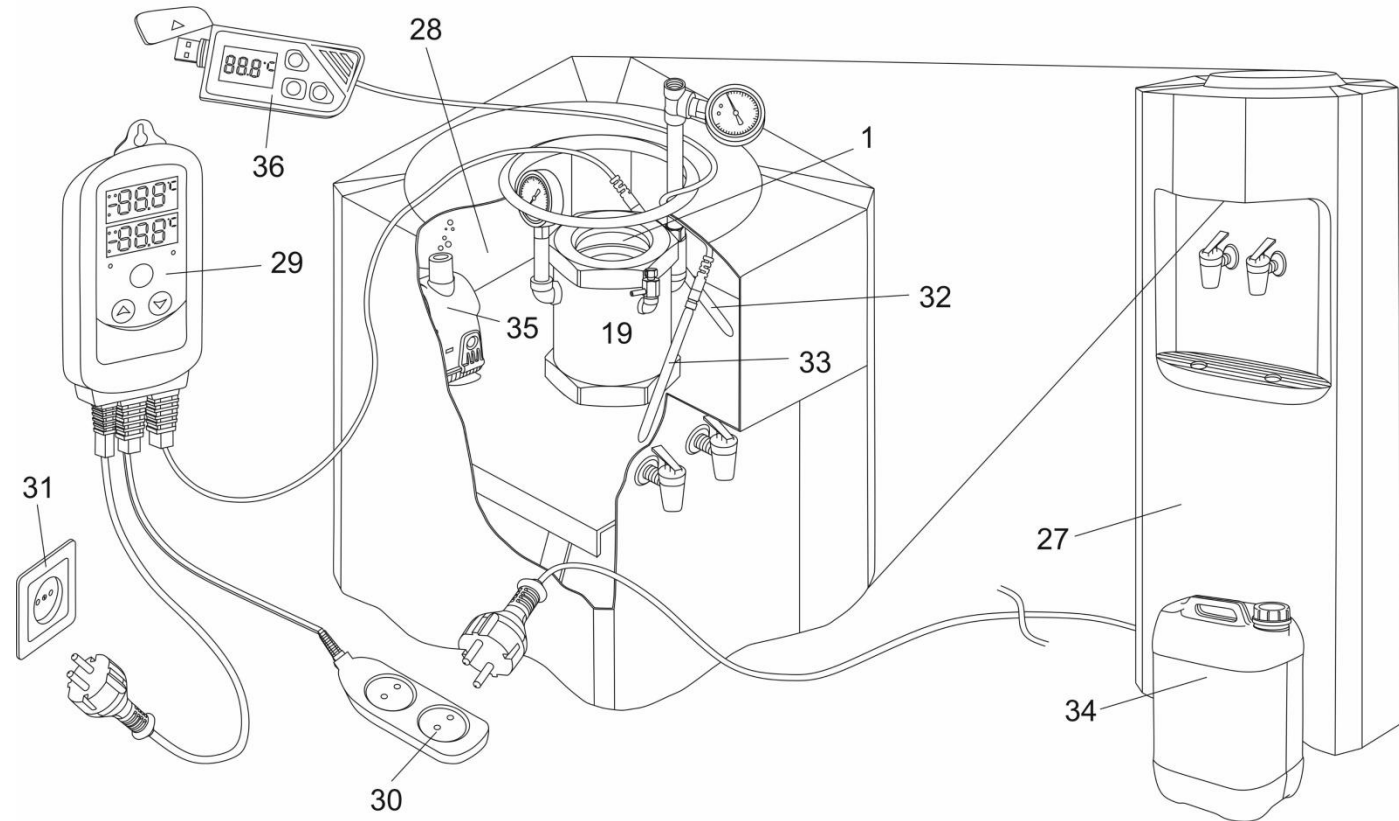

Zaključak



Kratkotrajna
proizvodnja

Dugoročna
proizvodnja

Proizvodni problemi

Tehnički pridobive količine
 $190 \cdot 10^{12} - 700 \cdot 10^{12} \text{ m}^3$

Inženjeri



CAPEX & OPEX

Reference:

1. Boswell, R., Hancock, S., Yamamoto, K., Collett, T., Pratap, M., Lee, S-R. (2020): Natural Gas Hydrates: Status of Potential as an Energy Resource. *Future Energy (Third Edition)*, 111-131. <https://doi.org/10.1016/B978-0-08-102886-5.00006-2>
2. Chen, Y-A., Chu, L-K., Chu, C-K., Ohmura, R., & Chen, L-J. (2019): Synthesis of Methane Hydrate from Ice Powder Accelerated by Doping Ethanol into Methane Gas. *Sci Rep*, 9, 12345. <https://doi.org/10.1038/s41598-019-48832-8>
3. Chen, L., Merey, S. (2021a): Emerging technologies in methane hydrate projects. *Oceanic Methane Hydrates*, 13, 349-390. <https://doi.org/10.1016/B978-0-12-818565-0.00012-4>
4. Chen, L., Merey, S. (2021b): Comparisons of field activities in different worldwide sites. *Oceanic Methane Hydrates*, 12, 333-348. <https://doi.org/10.1016/B978-0-12-818565-0.00011-2>
5. Chen, X., Lu, H., Gu, L., Shang, S., Zhang, Y., Huang, X., Zhang, L. (2022): Preliminary evaluation of the economic potential of the technologies for gas hydrate exploitation. *Energy*, 243, 123007. <https://doi.org/10.1016/j.energy.2021.123007>
6. Gaidukova, O., Misyura, S., Strizhak, P. (2022): Key Areas of Gas Hydrates Study: Review. *Energies*, 15, 5, 1799. <https://doi.org/10.3390/en15051799>
7. Huang, C., Li, D., Liang, D., & Bo, W. (2024): Dynamic Effect of Drilling Fluid Filtrate Reducers on Hydrate Formation. *Energy Fuels*, 38, 2, 1181-1191. <https://doi.org/10.1021/acs.energyfuels.3c04144>
8. Islam, R. M. (2022): Unconventional reservoirs. *Reservoir Development*, 4, 267-531. <https://doi.org/10.1016/B978-0-12-820053-7.00007-X>
9. Jalili, A., Koliopoulos, G. A. (2025): A review of fundamentals, challenges, prospects, and emerging trends in hydrate-based desalination. *Npj Clean Water*, 8, 52. <https://doi.org/10.1038/s41545-025-00484-0>
10. Kossel, E., Bigalke, N. K., Deusner, C., Haeckel, M. (2021): Microscale Processes and Dynamics during CH4-CO2 Guest-Molecule Exchange in Gas Hydrates. *Energies*, 14, 6, 1763. <https://doi.org/10.3390/en14061763>
11. Li, B., Li, X-S., Li, G., Chen, Z-Y. (2015): Evaluation of gas production from Quilian Mountain permafrost hydrate deposits in two-spot horizontal well system. *Cold Regions Science and Technology*, 109, 87-98. <https://doi.org/10.1016/j.coldregions.2014.08.002>
12. Li, J-F., Ye, J-L., Q, X-W., Q, H-J., Wu, N-Y., Lu, H-L., Xie, W-W., Lu, J-A., Peng, F., Xu, Z-Q., Lu, C., Kuang, Z-G., Wei, J-G., Liang, Q-Y., Lu, H-F., Kou, B-B. (2018): The first offshore natural gas hydrate production tests in South China Sea. *China Geology*, 1, 1, 5-16. <https://doi.org/10.31035/cg2018003>
13. Uzelac, M., Malvić, T., Uzelac, L., Pašić, B. (2026): Origin and significance of methane hydrates and their generation under laboratory conditions. *Mining of Mineral Deposits*, 20, 1, 142-150. <https://doi.org/10.33271/mining20.01.140>
14. Makogon, Y. F. (2010): Natural gas hydrates - A promising source of energy. *Journal of Natural Gas Science and Engineering*, 2, 1, 49-59. <https://doi.org/10.1016/j.jngse.2009.12.004>
15. Majid, A. A. A., Worely J., Koh, C. A. (2021): Thermodynamic and Kinetic Promoters for Gas Hydrate Technological Applications. *Energy Fuels*, 35, 23, 19288-19301. <https://doi.org/10.1021/acs.energyfuels.1c02786>.
16. Nakajima, Y., Yamamoto, J., Takano, S., Yamamoto, M., Ono, M., Kanada, S., Otsubo, K. (2023): Morphological Observations of Gas Hydrate Formation in Gas-Seawater Systems. In Proceedings of the Thirty-third International Ocean and Polar Engineering Conference, Ottawa, Canada
17. Pang, X-Q., Jia, C-Z., Chen, Z-X., Shi, H-S., Chen, Z-H., Hu, T., Wang, T., Xu, Z., Liu, X-H., Zhang, X-W., Wang, E-Z., Wu, Z-Y., Pang, B. (2022): Reduction of global natural gas hydrate (NGH) resource estimation and implications for the NGH development in the South China Sea. *Petroleum Science*, 19, 1, 3-12. <https://doi.org/10.1016/j.petsci.2021.12.006>
18. Stauber, J. L., Chariton, A., Apte, S. (2016): Global Change. *Marine Ecotoxicology*, 10, 273-313. <https://doi.org/10.1016/B978-0-12-803371-5.00010-2>
19. Zhang, P., Zhang, Y., Zahng, W., Tian, S. (2022): Numerical simulation of gas production from natural gas hydrate deposits with multi-branch wells: Influence on reservoir properties. *Energy*, 238, Part A, 121738. <https://doi.org/10.1016/j.energy.2021.121738>
20. Zhai, J., Li, X., Wu, Y., Shang, L., Bai, J. (2022): Effect of pressure on methane hydrate formation in graphite nanofluids in non-stirred system. *Journal of Dispersion Science and Technology*, 44, 14, 2683-2691. <https://doi.org/10.1080/01932691.2022.2122492>
21. Wan, T., Li, Z., Yu, Y., Liang, Q., Lu, H., Wang, J. (2023): Depressurization-induced gas production from hydrate reservoirs in the Shenhu sea area using horizontal well: Numerical simulation on horizontal well section deployment for gas production enhancement. *Earth Sci.*, volume 11. <https://doi.org/10.3389/feart.2023.1137217>
22. Wei, N., Pei, J., Zhao, J., Zhang, L., Zhou, S., Luo, P., Li, H., Wu, J. (2022): A state-of-the-art review and prospect of gas hydrate reservoir drilling. *Earth Sci.*, 10. <https://doi.org/10.3389/feart.2022.997337>
23. Yamamoto, K., Boswell, R., Collett, T. S., Dallimore, S. R., Lu, H. (2022): Review of Past Gas Production Attempts from Subsurface Gas Hydrate Deposits and Necessity of Long-Term Production Testing. *Energy & Fuels*, 36, 10, 5047-5062. <https://doi.org/10.1021/acs.energyfuels.1c04119>
24. You, K., Flemings, P. B., Malinvermo, A., Collett, T. S., Darnell, K. (2019): Mechanisms of Methane Hydrate Formation in Geological Systems. *Reviews of Geophysics*, 57, 4, 1146-1196. <https://doi.org/10.1029/2018RG000638>
25. Yu, Y., Shen, K., Zhao, H. (2024): Experimental Investigation of Fracture Propagation in Clayey Silt Hydrate-Bearing Sediments. *Energies*, 17, 2, 528. <https://doi.org/10.3390/en17020528>
26. Yu, Q., Tan, S., Luo, X., Wang, X., Zhang, H., Yu, Y., Yuan, J. (2026): Development of natural gas hydrates: A comprehensive review with focus on numerical simulation. *Energy Reports*, 15, 109025. <https://doi.org/10.1016/j.egyr.2025.109025>

Reference:



U.S. DEPARTMENT
of ENERGY



Internet sources:

- URL 1: <https://www.netl.doe.gov/sites/default/files/netl-file/2017-Methane-Hydrate-Primer%5B1%5D.pdf> (accessed on 8 March 2026)
- URL 2: https://netl.doe.gov/sites/default/files/publication/MHNews_2016_Spring.pdf (accessed on 15 March 2026)
- URL 3: https://www.mh21japan.gr.jp/english/mh21s_project.html (accessed on 10 March 2026)
- URL 4: <https://netl.doe.gov/sites/default/files/2020-02/NETL-Methane-Hydrate-Program-2000-2020.pdf> (accessed on 12 March 2026)
- URL 4: <https://netl.doe.gov/sites/default/files/2020-02/NETL-Methane-Hydrate-Program-2000-2020.pdf> (accessed on 12 March 2026)
- URL 5: https://netl.doe.gov/sites/default/files/publication/MHNews_2019_Spring.pdf (accessed on 14 March 2026)
- URL 6: <https://www.energy.gov/hgeo/articles/doe-and-international-partners-complete-gas-hydrates-production-testing-alaska-north> (accessed on 12 March 2026)
- URL 7: https://netl.doe.gov/sites/default/files/publication/MHNews_Spring2022.pdf (accessed on 20 March 2026)
- URL 8: https://netl.doe.gov/sites/default/files/publication/MHNews_Summer2023.pdf (accessed on 14 March 2026)
- URL 9: <https://science.nasa.gov/earth/earth-observatory/tracking-30-years-of-sea-level-rise-150192/?utm> (accessed on 20 March 2026)
- URL 10: <https://www.youtube.com/watch?v=3trDB5hN4Ug&t=201s> (accessed on 17 March 2026)
- URL 11: <https://ciencia.nasa.gov/ciencias-terrestres/el-deshielo-del-permafrost-podria-filtrar-microbios-y-productos-quimicos-al-medio-ambiente/> (accessed on 23 March 2026)
- URL 12: <https://www.usgs.gov/media/images/schematic-diagram-potential-manmade-hazards-related-gas-hydrates> (accessed on 28 March 2026)
- URL 13: <https://energyconsortium.org/co2-storage-in-gas-hydrate-a-potential-technology-for-carbon-sequestration/> (accessed on 1 April 2026)
- URL 14: https://www.mh21japan.gr.jp/english/gallery_pic/g_pic2022.html (accessed on 3 April 2026)
- URL 15: <https://netl.doe.gov/node/6971> (accessed on 3 April 2026)
- URL 16: https://www.usgs.gov/publications/new-insights-occurrence-and-implications-mobile-water-gas-hydrate-systems?utm_source=chatgpt.com (accessed on 5 April 2026)
- URL 17: <https://psl-systemtechnik.com/en/products/gas-hydrate-autoclave/#cffaktencheck> (accessed on 6 April 2026)
- URL 18: <https://www.youtube.com/watch?v=w8d38CXOoJw> (accessed on 10 April 2026)
- URL 19: <https://www.gns.cri.nz/research-projects/gas-hydrates/> (accessed on 10 April 2026)



Sveučilište u
Zagrebu



Sveučilište u Zagrebu
**RUDARSKO
GEOLOŠKO
NAFTNI FAKULTET**



DRŽAVNI ZAVOD ZA INTELEKTUALNO VLASNIŠTVO

Zahvala:

Ovo istraživanje dijelom je načinjeno u okviru NPOO projekta (unutar okvira programa Europske unije „Next Generation”) naslovljenog “Matematička istraživanja u geologiji” (akr. “Geomat”, engl. „Mathematical researching in geology”). Projekt financira Europska unija. Voditelj je T. Malvić. Izvodi se na Rudarsko-geološko-naftnom fakultetu Sveučilišta u Zagrebu, gdje se vodi pod (internim) brojem 581100002.

mh
maticahrvatska
Utemeljena 1842.



**Financira
Europska unija**
NextGenerationEU